

*For more info about compatibility with other models please see the sticker on the skid plate

TOYOTA FJ CRUISER

No.: 5789.1/6 Engine plate 1
5784.1/6 Engine plate 2
5785.1/6 Gearbox & transfer case

Year: 2010-

Engine: 4.0

Transmission: All

FITTING KIT

1. Bolt M8x30.....	2 pc
2. Bolt M10x30.....	12 pc
3. Bolt M10x110.....	2 pc
4. Nut M10.....	4 pc
5. Washer 8.....	2 pc
6. Washer 10.....	18 pc
7. Insert nut M10.....	2 pc
8. Insert brad M10.....	2 pc
9. Bracket 1.....	1 pc
10. Bracket 2.....	1 pc
11. Bracket 3.....	1 pc
12. Bar.....	1 pc

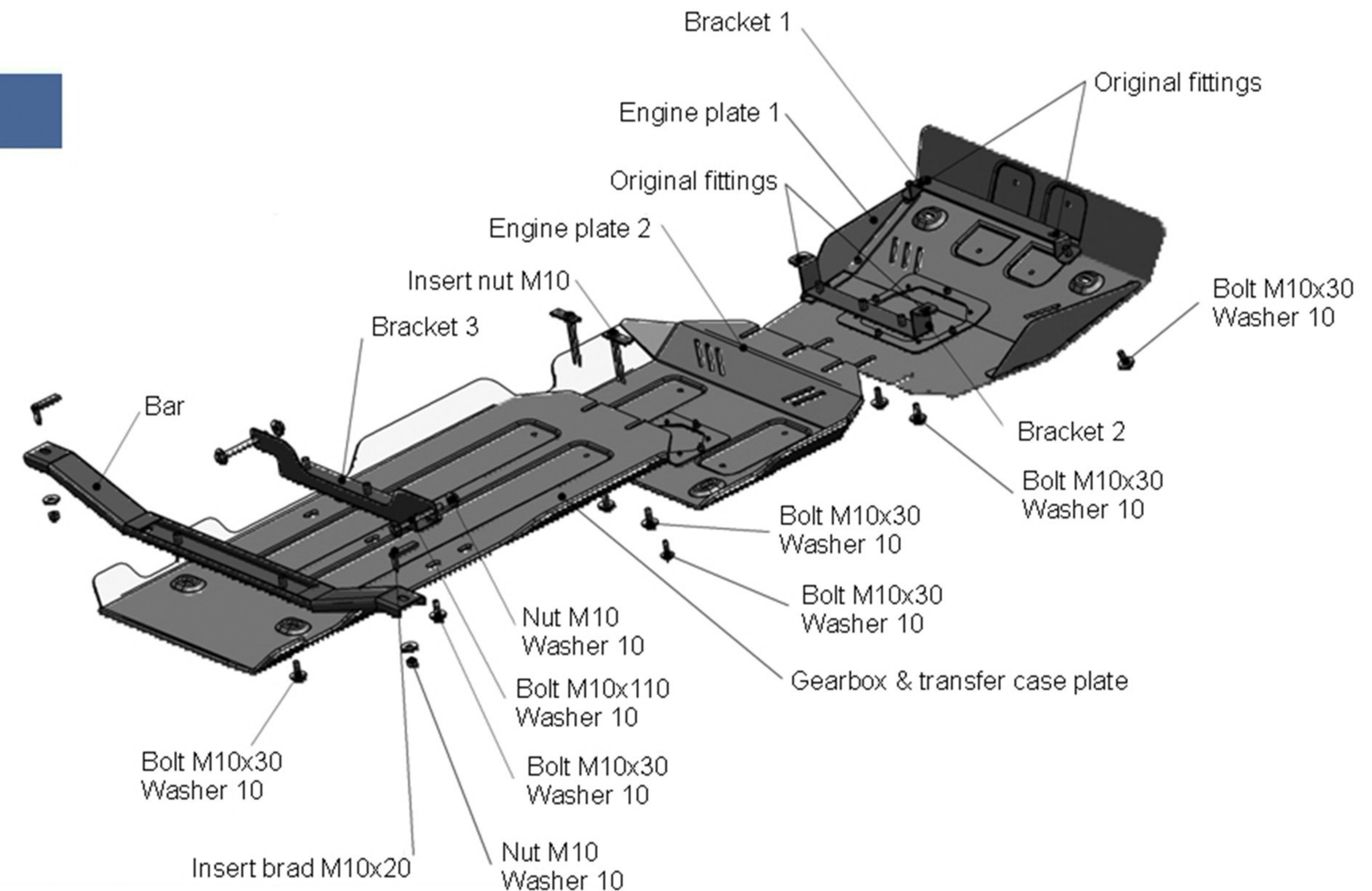

INSTALLATION INSTRUCTIONS

1. Remove original plastic cover.
2. Mount brackets 1 and 2 to the original threaded apertures with original fittings.
3. Screw bolts M10x30 into bracket 2, then place rear end of engine block plate 1 on mounted bolts M10x30. Fix the front end of the plate to bracket 1 with bolts M10x30.
4. Mount insert nuts M10 above the apertures of middle part of underframe.
5. Place front end of engine block plate 2 under rear end of engine block plate 1. Fix the rear end of engine block plate 2 to mounted insert nuts M10 with bolts M10x30, then fix it to original threaded apertures with bolts M8x30.
6. Fix bracket 3 to the cross-beam of the vehicle with bolts M10x110 and nuts M10. Mount insert brads M10x20 into apertures of underframe, then fix the beam 14 to them with nuts M10.
7. Place front end of gearbox & transfer case plate under the engine block plate 2, fix its rear end to mounted beam and bracket 3 with bolts M10x30.
8. Tighten all screws (50 Nm for M10, 30 Nm for M8, 10 Nm for M6). Use of pneumatic tools is prohibited.



WWW.RIVAL4X4.COM