

INSTALLATION MANUAL

PRODUCT: RECOVERY POINTS

MODEL: FORD RANGER (2022 - PRESENT)
FORD EVEREST (2022 - PRESENT)
FORD RANGER RAPTOR (2022 - PRESENT)

PART NO: 2D.1817.2



CAUTION!

To reduce the risk of serious injury or damage, please read and understand all instructions and procedures before attempting to install or use this product. Safety glasses must be worn at all times during installation or maintenance of this product. Ensure all mounting bolts are tensioned after 400 km and periodically thereafter.

NOTICE

Whilst the recovery points add additional protection to your vehicle, precautionary measures still need to be taken to avoid damage. Always drive to the conditions and your surroundings.

*RECOVERY POINTS



WARNING

Do not exceed the Working Load Limit of these recovery points or shackle.

INSPECTION AND SAFETY

Recovery of stuck vehicles can be dangerous. Always inspect the shackle and recovery points before each use. Do not use if there are visible signs of damage or wear including cracking (or elongation). Always stay a safe distance away from the recovery area - at least 1.5 times the length of the recovery strap. Incorrect use of receivers equipment can result in serious injury or death.

Always use recovery points as a matched pair teamed with an equalising bridle during any recovery situation.

Please attach this "Warning" label to the door aperture.

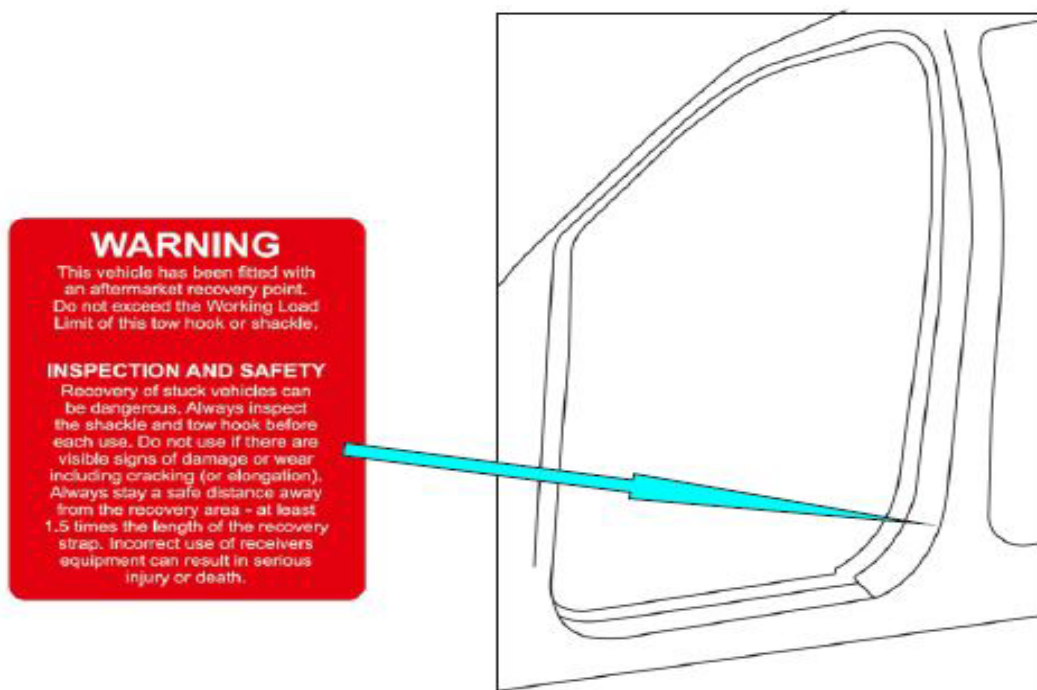

RECOVERY POINTS



Part number 2D.1817.2

Suited to vehicle: FORD RANGER (2022 - PRESENT)
FORD EVEREST (2022 - PRESENT)
FORD RANGER RAPTOR (2022 - PRESENT)

Material: Steel



SAFETY NOTICE

- * The RIVAL Recovery points is designed to compliment the use and design of the specified vehicle under conditions specified by the vehicle manufacturer.
- * While driving the vehicle at any speed, collision with any other vehicle, animal or object must always be avoided.
- * Following any collision with any other vehicle, animal or object, the RIVAL Recovery points and the vehicle must be inspected by a specialized or suitably qualified vehicle repairer for possible damage to the components and assemblies in order to confirm suitability for further use of the vehicle.
- * It is strongly recommended that you do not operate a vehicle with a damaged Recovery points or its components. In the case of damage, please contact the nearest RIVAL dealer. Vehicle, or where the Recovery points has been damaged, is extremely dangerous and must be avoided at all cost.
- * The operation of a vehicle where the Recovery points is not properly attached and fastened to the vehicle, or where the Recovery points has been damaged, is extremely dangerous and must be avoided at all cost.
- * It is recommended that you carry out regular inspections of all the Recovery points elements such as all bolts, wires, connectors.

INSTALLATION NOTICE

- * Personal safety during the installation process must be adhered to at all times and the use.
- * Estimated time for installation: 30 minutes.
- * The RIVAL Recovery points must be mounted and affixed to the vehicle according to this installation manual of personal safety equipment is highly recommended.
- * Do not install this Recovery points on vehicle models other than those allowed in this manual.
- * Check state and local highway safety laws regarding permitted recovery points types.

REQUIRED TOOLS

- * Basic tool kit
- * Torque wrench

TORQUE SETTING

- * M6 - 9 N·m
- * M8 - 24 N·m
- * M10 - 30 N·m
- * M12 - 77 N·m

PARTS LISTING

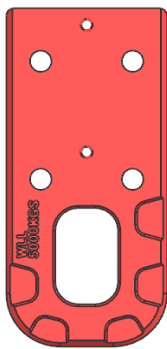
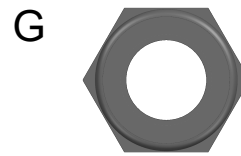
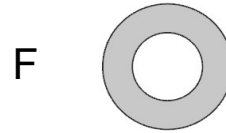
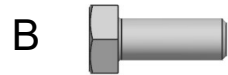
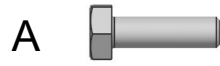

H

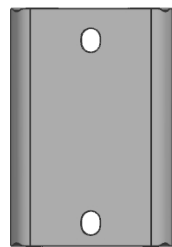

I

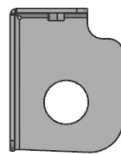

J

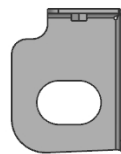

K



L

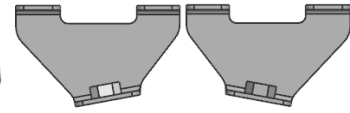

M

N

A. Bolt M6x20.....	Qty 4
B. Bolt M8x20.....	Qty 4
C. Bolt M12x50.....	Qty 8
D. Washer 6.....	Qty 4
E. Washer 8.....	Qty 4
F. Washer 12.....	Qty 16
G. Nut M12.....	Qty 8

H. Recovery point.....	Qty 2
I. Recovery point bracket.....	Qty 2
J. Left intercooler bracket.....	Qty 1
K. Right intercooler bracket.....	Qty 1
L. Bash plate bracket.....	Qty 2
M. Left bash plate bracket (Raptor).....	Qty 1
N. Right bash plate bracket (Raptor).....	Qty 1

INSTALLATION PROCEDURE

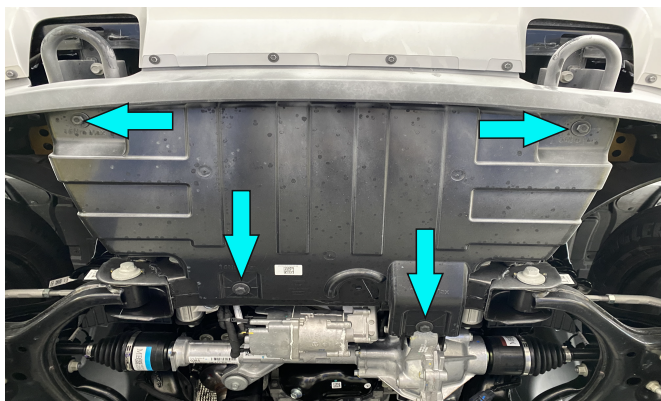

Fig.1

1. Unscrew OE bolts and remove OE plate (fig.1).

*** Set aside for re-use later on.**

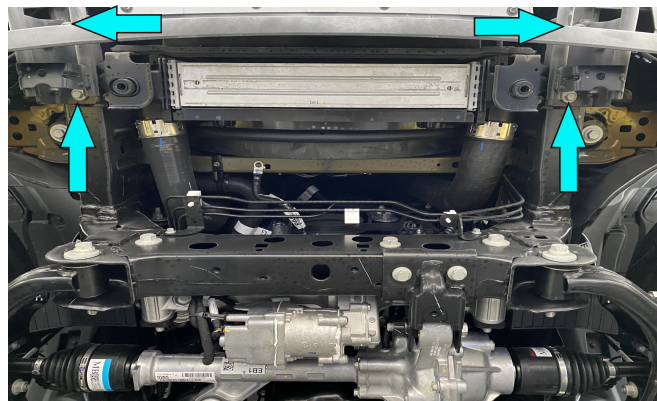

Fig.2

2. Fix intercooler using transmission jack, unscrew OE bolts after that and remove OE recovery points (fig.2)

*** Set aside for re-use later on.**

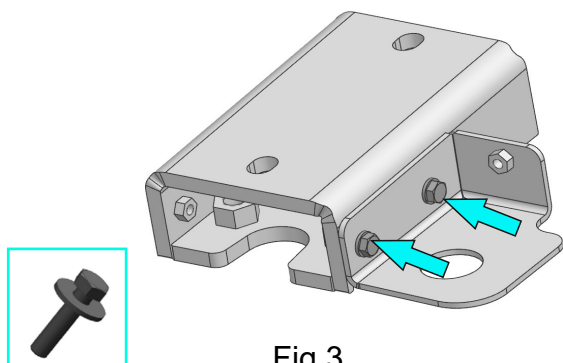

Fig.3

3. Install intercooler bracket (item J) on recovery point bracket (item I) and fix using bolts M6x20, washers 6 (item A, D) (fig.3).

***Tighten hardware after that.**

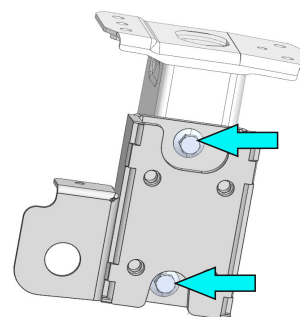

Fig.4

4. Install recovery point bracket (item I) on the left side of the vehicle and fix using OE bolts as shown in fig.4.

***Tighten hardware after that.**

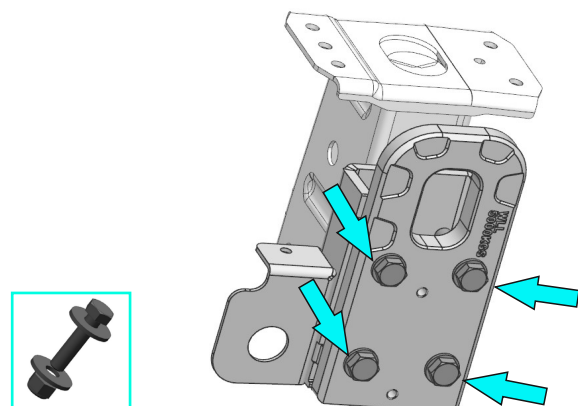

Fig.5

5. Install recovery point (item H) on recovery point bracket (item I) and fix using bolts M12x50, washers 12, nuts M12 (item C, F, G) (fig.5).

***Tighten hardware after that.**

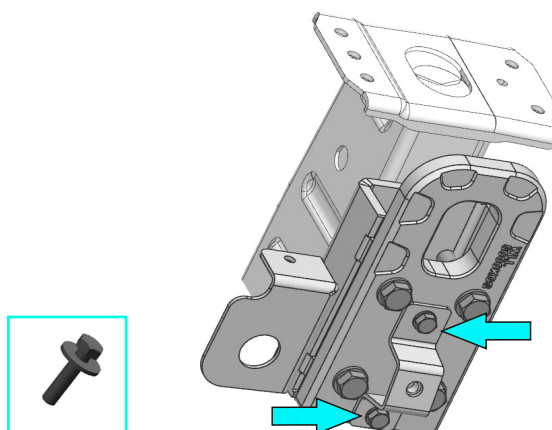

Fig.6

6. Install bash plate bracket (item L) on recovery point (item H) **for Ranger and Everest**. Fix using bolts M8x20, washers 8 (item B, E) (fig.6).

***Tighten hardware after that.**

INSTALLATION PROCEDURE

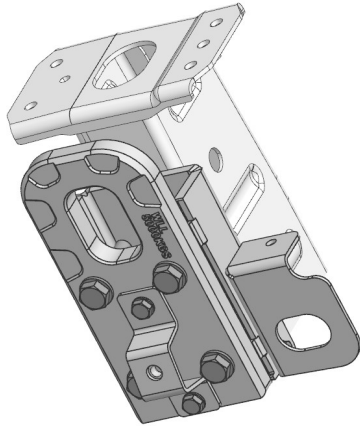

Fig.7

7. Similarly install on the right side of vehicle (**Ranger and Everest**) (fig.7).

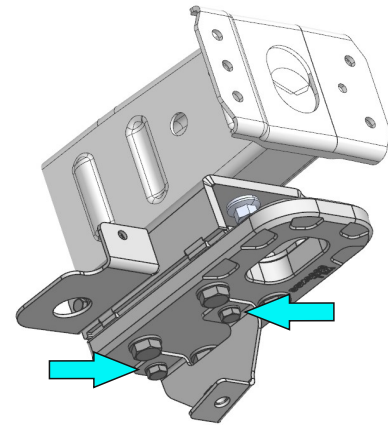

Fig.8

8. Install left bash plate bracket (item M) on recovery point (item H) **for Ranger Raptor**. Fix using bolts M8x20, washers 8 (item B, E) (fig.8).

***Tighten hardware after that.**

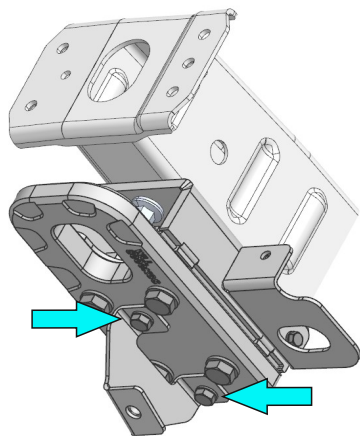

Fig.9

9. Install right bash plate bracket (item N) on recovery point (item H) **for Ranger Raptor**. Fix using bolts M8x20, washers 8 (item B, E) (fig.9).

***Tighten hardware after that.**

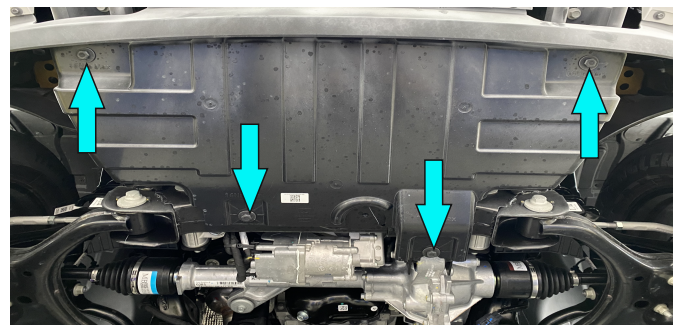

Fig.10

10. Install OE plate and fix it using OE hardware (fig.10).

INSTALLATION PROCEDURE



Before operating a vehicle fitted with RIVAL Recovery Points 2D.1817.2:

- make sure all fittings are tightened
- check winch operation
- check that all electrical wiring is attached to the lights

